

WATSON ARTS CENTRE EXHIBITION SERVICE

FEE SCHEDULE FOR SELLING EXHIBITIONS 2010

(all prices quoted below include gst where applicable)

Fees for non-selling exhibitions are by negotiation

This document should be read in conjunction with the Watson Arts Centre Agreement for Exhibition Services.

PLEASE NOTE THAT THERE IS A MINIMUM EXHIBITION PERIOD OF TWO WEEKS.

1. **Service fee - \$370 for the first week, \$360 for the second week and \$345 per week for subsequent weeks**, payment of which gives:

1. Use of the Watson Arts Centre gallery for an exhibition.
2. Use of the gallery's plinths and partitions.
3. Use of the Centre's kitchen, foyer and verandah for an opening event.
4. Provision by Watson Arts Centre of postcard size invitations (full colour on one side), with a quantity being provided to the exhibitor(s) to distribute, the remainder being mailed with a current newsletter to the Canberra Potters' Society membership and distributed to local outlets (e.g. Canberra Visitors' Centre, Craft ACT, etc).

Variations to the invitation format, e.g. different size or an additional quantity, may be arranged but at cost to the exhibitor(s).

We can provide address labels from our mailing list upon request.

5. Promotion of the exhibition through Canberra Arts Marketing, the Canberra Potters' Society web site, various local web sites, a media release, the Centre's usual listings in the Canberra Times and any other promotional outlet that the Centre may consider appropriate.
6. Distribution of the exhibition's details to the Watson Arts Centre and Canberra Potters' Society email mailing lists.
7. A simple, photocopied catalogue listing exhibits and their prices.
8. Minding and sales handling of the exhibition by Watson Arts Centre with the exhibition open to the public during the Centre's normal opening hours (currently 10am – 4pm Thursday to Sunday and most public holidays). Sales will also be handled during the exhibition's opening event if there is one, and during a purchase collection time specified by Watson Arts Centre.

2. **Sales commission – 22% of an item's retail price will be retained by Watson Arts Centre.**

Commission will be deducted from sale proceeds, the net balance being paid by cheque to the exhibitor(s) as soon as practicable after the close of the exhibition. *(See clauses 3 and 4 of the agreement.)*

3. **Cleaning bond - \$50**

The cleaning bond will be refunded at the end of the exhibition provided that no additional expense has been incurred by Watson Arts Centre in making good any damage to the gallery, kitchen, foyer, verandah, store rooms, plinths, partitions, etc. due to the exhibition's installation, or for any cleaning, rubbish removal, etc. due to either the exhibition's installation or an opening event. *See clauses 7, and 8 of the agreement and points 3 and 5 under 'Exhibitor's Responsibilities' below.*

EXHIBITOR'S RESPONSIBILITIES

1. Delivery of exhibition pieces to Watson Arts Centre, and installation of the exhibition, from the installation date specified in the agreement, including numbering/labelling all exhibits in accordance with the details provided to Watson Arts Centre for the catalogue.

2. Demounting, packing and removing all unsold work by the date/time specified in the agreement.
3. Making good, by the end of the exhibition demounting date, any damage to walls, partitions, plinths, floor, etc. caused by the exhibition's installation.
4. Organisation of an opening event if one is to be held, including, if required, arranging for someone to perform the exhibition opening.
5. Cleaning the kitchen, foyer, verandah and gallery as necessary after an opening event, including removing all rubbish, bottles, left-over food, etc.
6. Providing to Watson Arts Centre by, at the latest, the installation date set out in the agreement, details of all exhibits for the preparation of a catalogue. These details should include for each item:
 - a. A unique identifier, this identifier to also be on a sticky label attached to the base of, or in some unobtrusive place on, the item. *(Mandatory)*
 - b. The retail price including the 22% commission that will be retained by Watson Arts Centre if an item is sold. *(Mandatory)*

If an exhibitor is registered for GST the retail price must include GST. In this case, commission will be calculated on the retail price less its GST component. It is the exhibitor's responsibility to pay to the Australian Tax Office the GST component of the retail price of any item sold.
 - c. A brief description of the piece. *(Optional)*
7. Providing to Watson Arts Centre, at least three weeks before the installation date but preferably earlier, an artist's statement (for each exhibitor if a group exhibition) on which a media release and other promotional material can be based.
8. Providing to Watson Arts Centre by a specified date an image, or images, for the invitation and for use on web sites.
9. It is in an exhibitor's own interests to be prepared to speak to the media if approached for an interview.
10. Each exhibitor must provide Watson Arts Centre with their GST status and either their ABN or a declaration acceptable to the Australian Tax Office of their tax status (eg hobbyist, overseas visitor, etc.).

EXHIBITOR'S ADDITIONAL COSTS

1. All packing, delivery, installation, demounting and removal costs.
2. Insurance, if required, of exhibits whilst in transit and/or on the Watson Arts Centre premises.
3. All costs associated with an opening event, eg food, wine, flowers, etc.
4. All costs associated with mailing out those invitations provided to the exhibitor(s).
5. Costs for any other function or facility not explicitly included in the fee schedule.

Watson Arts Centre

1 Aspinall Street, Watson

MAIL: PO Box 7021, WATSON, ACT 2602

PHONE/FAX: (02) 6241 1676

E-MAIL: wcac@canberrapotters.com.au

WEB: <http://www.canberrapotters.com.au/wcac.html>

APPLICATION FOR EXHIBITION SERVICES AT WATSON ARTS CENTRE GALLERY

Solo exhibitor or, for a group exhibition, main contact:

Name _____
Address _____
_____ State _____ Postcode _____
Phone _____ (bh) _____ (ah) _____ (mob)
Email _____

(Proposed) exhibition dates: (please note that a minimum exhibition period of two weeks applies.) Before signing the agreement that follows this application, the exhibition proposal and dates must be confirmed by the WAC Program Manager.

Installation date: _____ Demounting date: _____

Opening date: _____ Closing date: _____

Opening event: _____

e.g. date, time, to be opened by (if information not yet available, please supply when it is)

Title of the exhibition: _____

If you have one, your web site URL: _____

A brief proposal for the exhibition (eg curatorial rationale, concept, idea), artist statement(s) and CV(s) should accompany this application. Details of any technical requirements should also be supplied along with a drawing/layout of installation if appropriate. Visual material (eg slides, images as prints or on CD) can be sent with the application or electronic images can be emailed to wcac@canberrapotters.com.au.

In the case of a group exhibition, each exhibitor must sign the last page of the agreement when the proposal and dates have been confirmed.

This agreement should be read in conjunction with the Exhibition Service Fee Schedule.

Payment of the first week's exhibition service fee (for exhibitions of two weeks) or 50% of the agreed fee (for exhibitions longer than two weeks) plus a \$50 cleaning bond is required to secure the exhibition booking. An invoice will be sent when the proposal and dates have been confirmed. The balance will be payable 14 days prior to the exhibition installation date.

AGREEMENT FOR EXHIBITION SERVICES AT WATSON ARTS CENTRE GALLERY

DEFINITIONS

- TERRITORY refers to the Australian Capital Territory, the registered proprietor of the Watson (Community) Arts Centre.
 - MANAGERS refers to Canberra Potters' Society Inc., the lessee of the Watson (Community) Arts Centre.
 - WAC means Watson (Community) Arts Centre.
- 1 This agreement between the Canberra Potters' Society Inc. and the Exhibitor(s) identified on the application forming page 1 is for the provision of Exhibition Services by the Managers for an exhibition in the WAC Gallery for the period specified on the front page of this agreement.
 - 2 The agreed fee for this service is \$ (inc. GST). The agreement is not secure, and no action will be taken by the Managers in providing for the exhibition, until a deposit equivalent to the first week's exhibition service fee (for exhibitions of two weeks) or 50% of the agreed fee (for exhibitions longer than two weeks) is paid. The balance, if any, is payable 14 days prior to the installation date specified on the front page of this agreement.
 - 3 The Exhibitor(s) appoint(s) the Managers as their agent for the purpose of sale of the exhibited works in this exhibition. During the period of the exhibition, customer orders or commissions for new work by the Exhibitor(s) that are received or initiated by the Managers are deemed to be covered by this agreement. The Managers will not act as the exclusive agent for any other works by the Exhibitor(s).
 - 4 The Managers, as agent, makes sales on behalf of exhibitors. When work is sold the exhibitors in effect enter into a contract with the customer, with the Managers acting as an intermediary on behalf of the exhibitors. For this service the Managers charge commission on all sales at the rate of 20% plus GST (ie 22% overall) of an item's retail price (or the retail price less its GST component if the Exhibitor is registered for GST).
 - 5 All Exhibitors understand that, if registered for GST, their retail prices provided to the Managers must include GST and that it is the GST-registered Exhibitor's responsibility to pay to the Australian Tax Office the GST component of the retail price of any items sold.
 - 6 Items sold whilst on exhibition will be paid for in a single payment (less commission – see clause 4) as soon as practicable after the close of the exhibition, with the exception of sold items, orders or commissions for which only a deposit has been paid at this time – these will not be paid for until full payment has been received from the customer.
 - 7 A \$50 cleaning bond is required and will be included in the initial invoice. The cleaning bond will be refunded as soon as practicable after the demounting date provided that the gallery, kitchen, foyer, verandah and store rooms are left in a clean and tidy state and that plinths, partitions, gallery walls and floor, etc. have been returned to the state they were in prior to the exhibition installation. Broken glasses from the kitchen should be replaced.
 - 8 The exhibitor licenses the Managers to edit and use photographs, images and texts for use in publicity material about the exhibition, the Canberra Potters' Society Inc and Watson Arts Centre.
 - 9 **No** double-sided sticky tape, mirror tape, or velcro dots are to be used on the gallery walls, partitions or plinths (use of these will cause the cleaning bond to be forfeited). A limited number of hangers are available for hanging items from the picture rails. If removable adhesives, eg BluTack, are used, all traces must be removed. Catalogue numbers must be removed from plinths, walls, partitions and floors when demounting the exhibition.
 - 10 Any damage to the walls, partitions, floor and plinths must be made good. Holes must be filled, sanded back and repainted. Plinths, walls and partitions are not to be painted with anything other than the paint specified by the Managers. Before repainting anything, the Managers should be notified so that the correct paint can be confirmed.
 - 11 In the event of cancellation (whether in writing or otherwise), any deposit paid by the Exhibitor(s) shall be forfeit unless said cancellation is more than 3 months prior to the installation date. Cancellations more than 3 months prior to the installation date shall attract a cancellation fee of \$25.
 - 12 The Managers reserve the right to reject work from exhibition in the Gallery if the work is deemed unsuitable.
 - 13 The Exhibitor (or Exhibitors in the case of a group exhibition) will be solely responsible for the hanging/installation of the exhibition and its demounting and removal. Any specific requirements the Exhibitor(s) may have concerning the installation of the exhibition that may impact on the plinths, partitions, etc. should be discussed with the Managers and authorisation obtained prior to the installation date.

- 14 Late installation of works and/or late provision of catalogue/sales listing information may result in exclusion of those works from the catalogue/sales list.
- 15 The Exhibitor(s) will remove all work by the demounting date/time specified on the front page of this agreement.
- 16 The Exhibitor (or one of the Exhibitors in the case of a group exhibition) will be provided with keys for gaining access to the WAC premises. Full security instructions will be provided. The Exhibitor(s), upon entry to the premises, must carry out any security for the premises and upon leaving, must turn off all lights and heaters/air conditioners, secure doors, and arm the security system. In the case of an alarm being activated by the Exhibitor(s) or anyone given access to the premises by the Exhibitor(s) necessitating a security call out, any costs shall be borne by the Exhibitor(s). Keys are to be returned to the Managers at the end of the exhibition demounting in the manner specified by the Managers.
- 17 The Exhibitor(s) will be liable for any damage incurred to WAC resulting from the installation or removal of the exhibition.
- 18 The Exhibitor(s) understand(s) that insurance of exhibits whilst on the WAC premises or in transit to or from the premises is the Exhibitor's responsibility. Neither the Managers nor the Territory accept any responsibility for exhibits.
- 19 Neither the Managers nor the Territory can be held liable or responsible for damages incurred to Exhibitor's equipment.
- 20 If failure or fault occurs in the period between installation and demounting in the mechanical systems, electricity supply or lighting of WAC, neither the Territory nor the Managers shall be liable for any loss or damage to exhibits or equipment supplied by the Exhibitor occasioned thereby.

Signature of Exhibitor 1 *(as detailed on page 1)*:

Signed for & on behalf of Canberra Potters' Society Inc:

Name

Name

Signature

Signature

Date

Position

Business name *(if appropriate)*

Date

ABN *(if applicable)*

GST registered? YES / NO *(please circle)*

Signature of Exhibitor 2 *(if applicable)*:

Signature of Exhibitor 3 *(if applicable)*:

Name

Name

Signature

Signature

Address

Address

.....

.....

Business name *(if appropriate)*

Business name *(if appropriate)*

Phone(s)

Phone(s)

Email

Email

Date

Date

ABN *(if applicable)*

ABN *(if applicable)*

GST registered? YES / NO *(please circle)*

GST registered? YES / NO *(please circle)*

After having been signed by the Exhibitor(s) and on behalf of Canberra Potters' Society Inc. a copy of this agreement will be returned to the Exhibitor(s).

Watson Arts Centre gallery

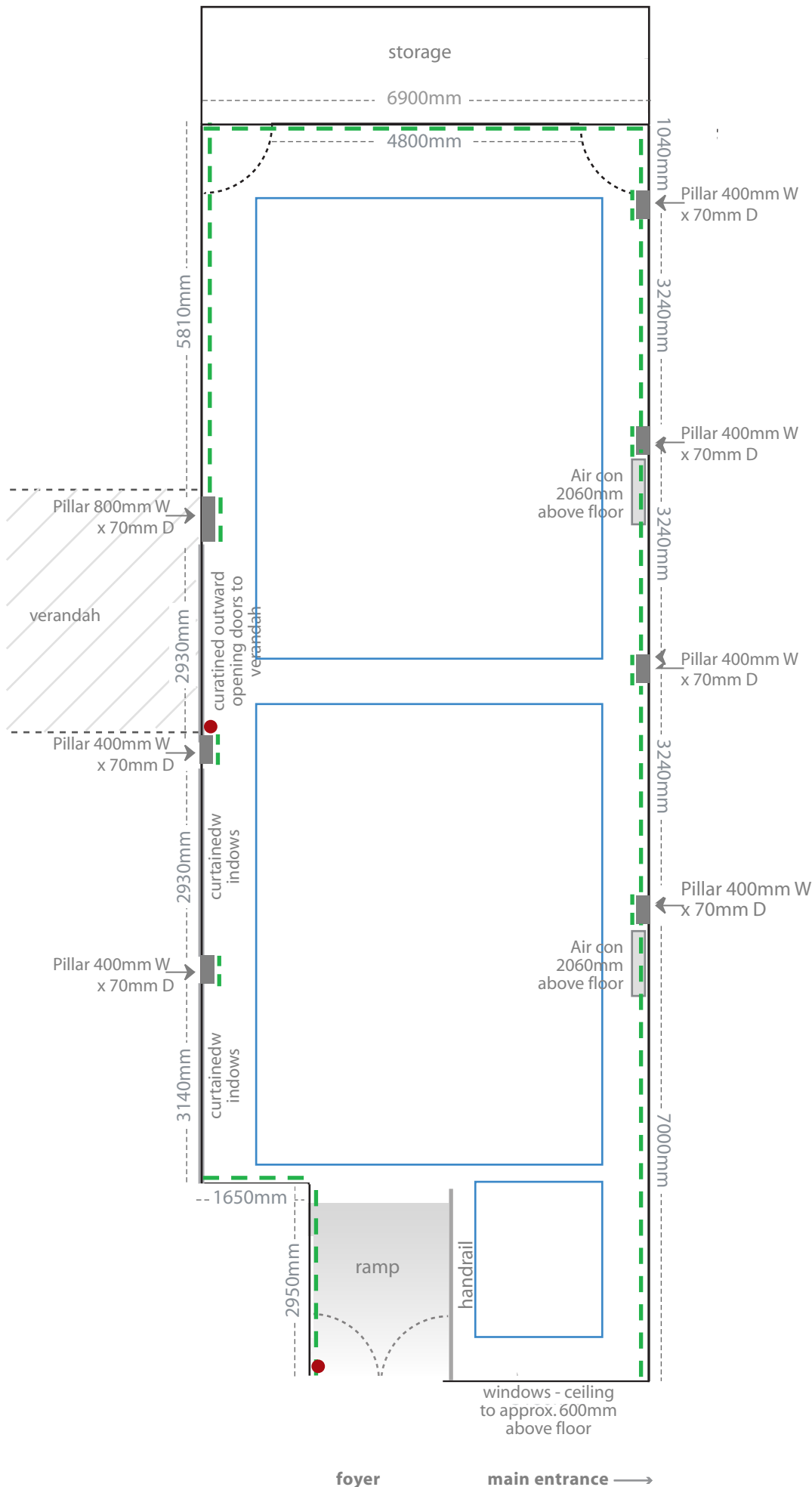

Ceiling height 2.52m

Overall gallery length 19.3m

Floor area 129m²

Total running length 50m (approx. including mobile partitions)

Walls painted white

Floor concrete, painted dark taupe

Ceiling painted white

Lighting wall washers and spot lights; fluorescent tubes

Partitions 3 mobile custom-wood partitions 2290mm H x 2300mm W x 400mm D; can be used for hanging as well as partitioning the gallery

Windows/doors along left-hand side have cream curtains; doors open onto outside

Storage room at end of gallery accessible through outward-opening doors on either side of the gallery

● Fire extinguisher

--- Hanging rail

□ Track lighting *not to scale*

Watson Arts Centre gallery equipment

Mobile partitions X 3

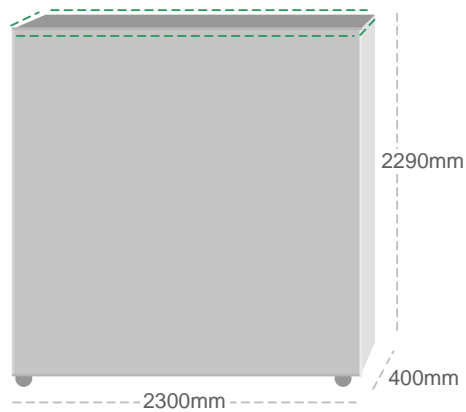

- Hanging rail right round top
- Castors for mobility
- Painted same colour as gallery walls (currently white)
- Made of custom-wood

Plinths

All plinths are made from custom-wood, are painted white and have open bases.



Width: 600mm
Depth: 600mm
Height: 400mm
Number: 8

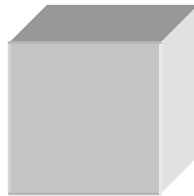

Width: 600mm
Depth: 600mm
Height: 600mm
Number: 8



Width: 900mm
Depth: 900mm
Height: 600mm
Number: 4



Width: 400mm
Depth: 400mm
Height: 900mm
Number: 16



Width: 400mm
Depth: 400mm
Height: 1100mm
Number: 6



Width: 400mm
Depth: 600mm
Height: 900mm
Number: 8

Glass Tops for Plinths

2 – 615mm x 615mm x 615mm

2 – 415mm x 415mm x 415mm

Tops fit over the 600mm x 600mm and 400mm x 400mm plinths, sitting on screws screwed into the top corners of the plinths.

Hanging wires/hooks

<i>Wires</i>	<i>Sliding hooks</i>
80+	Approx. 78